

Logomatic Series 900

Industrial build quality

/ Maximum sized label rolls (1,200 m)

/ 3 side application (pallets)

Industrial Print & Apply /// logopak.com



Logomatic Series 900

High speed P&A pallet/case labelling solution

Models

- / 910: for labels to 110 mm width
- / 920: for labels to 210 mm width
- / 930: for labels to 300 mm width

Printing characteristics

- / Thermal direct or thermal transfer printing method for labels up to A3
- / Print resolution: 203 dpi or 300 dpi

Label material

- / Running length: up to 1,200 m
- / Outer diameter: 480 mm
- / Label core: 76/152 mm
- / Low material warning

Operation

- / 5" touchscreen function for numeric entry
- / Optional: HMI 10" colour display
 - with touchscreen function
 - with alphanumeric entry
 - multilingual user interface
 - current label display

Interfaces

- / Integrated Ethernet port
- / High-speed RS-232 or RS-422 (optional: plus 2x RS-232 or RS-422)
- / Digital I/O (potential-free outputs)

Standard functions

- / Standard barcodes and 2D codes
- / Logos and graphics
- / Internal article database
- / Integrated real-time clock
- / Individually programmable counters
- / Fault diagnosis
- / Compressed air monitoring
- / Maintenance interval display

Ambient conditions

- / Operating temperature: 5 °C – 37 °C
- / Humidity: 20 % – 85 % relative, non-condensing
- / Electrical connection: 100 – 240 Volt; 50 – 60 Hz
- / Compressed air: 6 bar 1/2" BSP fixed, oil & water free

Frames and protective enclosure

- / H foot frame
- / Optional: machine enclosure made from steel plate, with inspection windows, service doors and automatic flap control

Certificates

- / CE certified (EU)
- / Optional: TR/EAC (RU)
- / Optional: SASO (SA)
- / Optional: UL 508 (US)

Additional options

- / RFID
- / Barcode verification (Vericoder)
- / Barcode validation (Scanner)
- / Alarm pole
- / Profibus/Profinet
- / Emergency stop
- / Height and side adjustment (manual/automatic)
- / Customer specific rest pallet handling
- / Special solutions for demanding ambient conditions
- / Enclosure in stainless steel and special colours available
- / Software:
 - Middleware package: LogoSoft
 - Label design: LEAP Express
 - Management: LogoRemote
 - Real-time connectivity
 - Stand-alone

Spare parts/maintenance

- / Full spare parts available worldwide
- / Proven life expectancy of 10 years +
- / Bespoke service support and preventive maintenance
- / Telephone support

Models 910/920/930

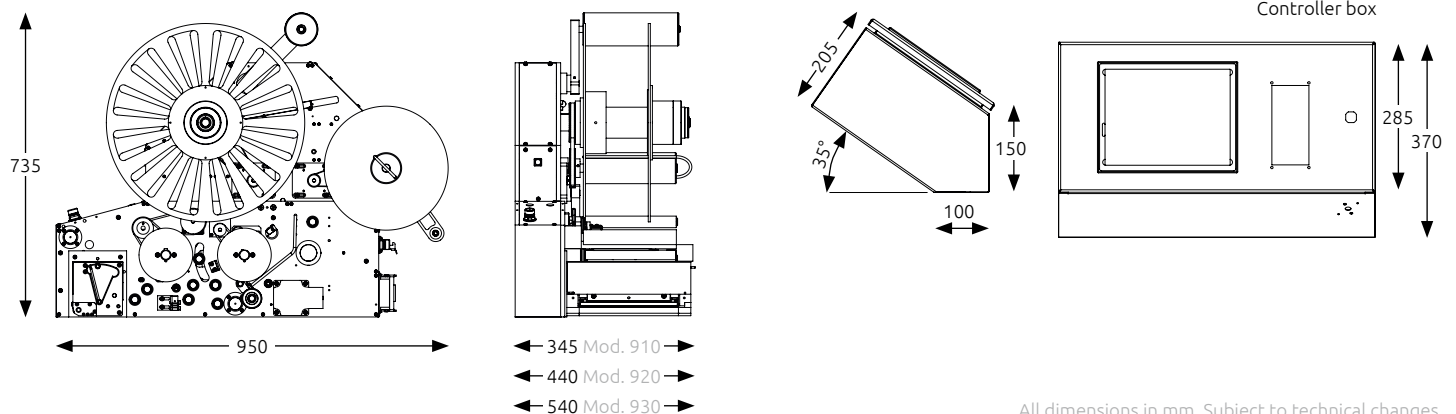

All dimensions in mm. Subject to technical changes.