

# MCP 140T

Marcopack's **MCP 140** wrap-around labeling machine offers effective, flexible and economic solutions for cylindrical products such as tubes, glass bottles, ampoules, etc. It is best defined by its versatility and adaptability to a wide range of product diameters. An Electro-pneumatic Top Stabilization system is included to ensure proper labeling of products.

Labels roll max diameter: 300mm. Labels max width: 200mm.

Front and back labeling are possible provided that both labels are in the same labels roll.

Independent traction system to allow place the label always in the same position.

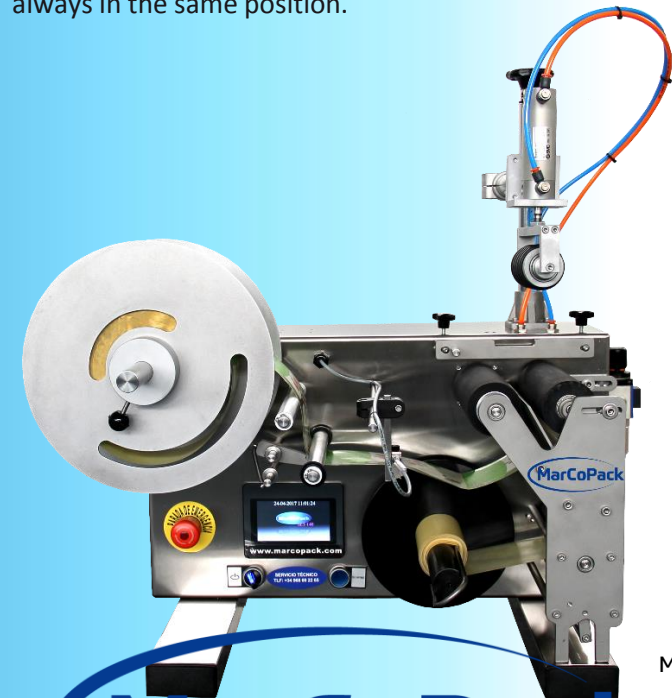
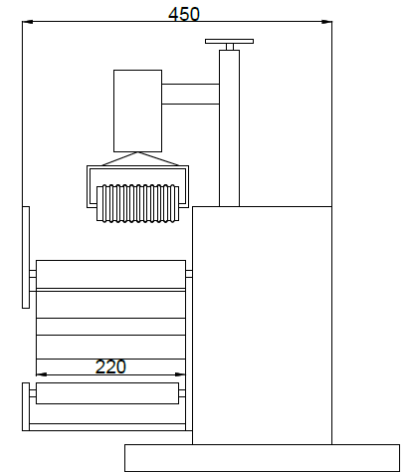
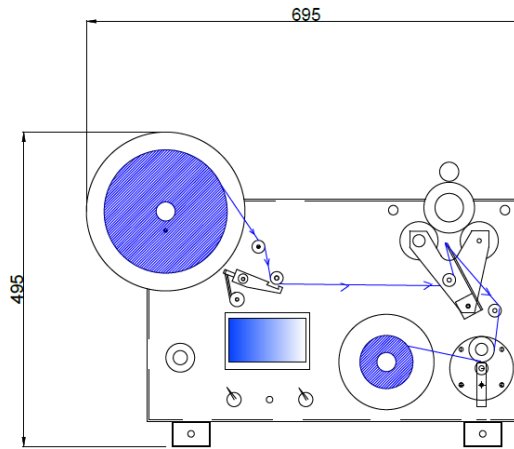

## CHARACTERISTICS

**Production speed:** maximum 30 packs per minute.

**Dispensing speed:** 25 meters per minute as maximum.

**Label length size:** 12mm - indeterminate.

**Label width size:** 10mm – 205mm.

**External diameter labels:** 300mm.

**Inside reel diameter:** 40 or 76mm.

**Motorization:** Geared motor.

**Product size:** Ø 40mm to Ø 120mm. Standard, ask for different sizes.

**Power supply:** 230 V, 50 – 60 Hz.

**Compressed air:** 5 Bars

**Touch:** Screen.

**OPTIONAL:** Possibility to apply front and back label by programming, front and back label will be placed in the same roll. Thermoprinter to encode batch of products with packing date, expiry date (Hot stamping)

MARCOPACK, S.L. - P.I. Saladar I - Avd. Papá Ali s/n 30564 Lorquí (Murcia) Spain • Tlf.: +34 968 692 265 - Fax: +34 968 692 053  
www.marcopack.com - E-mail: [marcopack@marcopack.com](mailto:marcopack@marcopack.com)

Marcopack reserves the right to modify its design and specifications without incurring any obligation because this product is subject to continuous improvement.

# MarCoPack

