

MCP 99T

The MCP 99T equipment is a label applicator specially designed for high-performance applications. Highly versatile, it can be adapted to any production line, working horizontally or vertically. Robust and reliable, made of 15 mm thick laser-cut aluminium. It has a user-friendly colour touch screen. Label rewinding system and aluminium reel holder table. Applicator head with stepper motorisation.

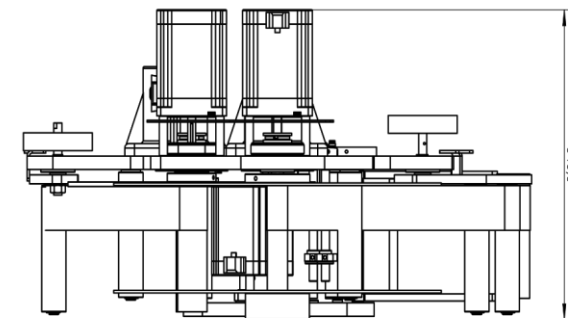
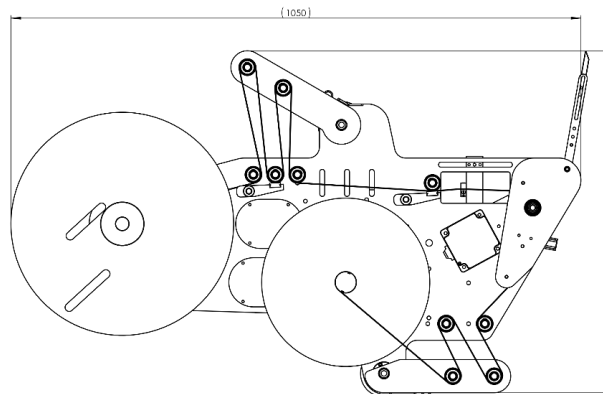

CHARACTERISTICS

Production speed: Maximum 22.000 per hour.

Dispensing speed: Up to 80 metres/minute.

Label length: 12mm indeterminate.

Label width: 120 or 200 mm maximum.

Label outer diameter: Up to 4 00mm

Label core diameter: 38 mm..

Motorisation: Stepper motor.

Power supply: 230 V, 50 60 Hz.

Optional:

- Tailor-made anchoring to adapt to different types of machines.

MARCOPACK, S.L. - P.I. Saladar I - Avd. Papá Ali s/n 30564 Lorquí (Murcia) Spain • Tlf.: +34 968 692 265 - Fax: +34 968 692 053
www.marcopack.com - E-mail: marcopack@marcopack.com

Marcopack reserves the right to modify the design and specifications of this machine, as it is a product under continuous development.



MarCoPack

