

MCP 60T

Marcopack's MCP 60T is a Label Applicator especially designed for high-performance applications with user-friendly touch-screen control panel. Robust and reliable, Label head made of stainless steel. The label head uses a steel rolling system, With a base made of stainless steel cut by laser in only one piece. Labeling system to apply from top, lateral or bottom.

Regulation of the head labeler by a 256 color touch screen. You can place the label by controlling different parameters like speed, start and stop of the label. Label break alarm and label,

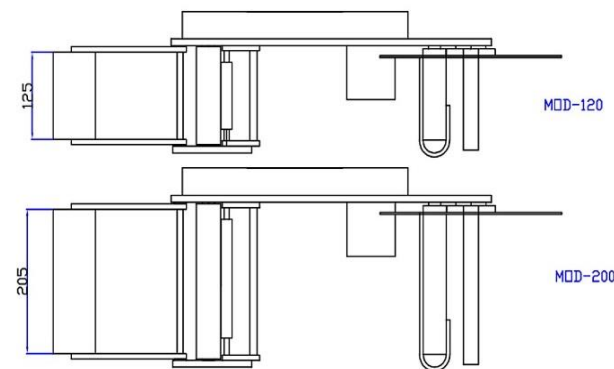
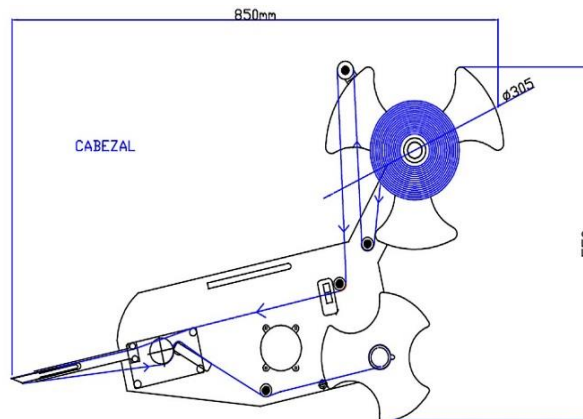

CHARACTERISTICS

Production speed: 18.000 max per hour.

Dispensing Speed: 50 meters per minute.

Label length size: 12mm - indeterminate.

Label width size: 10mm minimum – 120mm – 205mm maximum according to the model.

External diameter label: 300mm. 400mm Optional.

Inside reel diameter: 40 or 76mm.

Motorization: Step by step motors.

Compressed air: 6 bars with thermoprinter.

Power supply: 230 V, 50 – 60 Hz.

OPTIONAL:

- Electro-pneumatic system devised to encode pr

MARCOPACK, S.L. - P.I. Saladar I - Avd. Papá Ali s/n 30564 Lorquí (Murcia) Spain • Tlf.: +34 968 692 265 - Fax: +34 968 692 053
www.marcopack.com - E-mail: marcopack@marcopack.com

Marcopack reserves the right to modify its design and specifications without incurring any obligation because this product is subject to continuous improvement



MarCoPack