

Technical specifications

LOGOMATIC Series | 900

Industrial build quality

- » Maximum sized label rolls (1,200 m)
- » 3 side application (pallets)

LOGOMATIC Series | 900

High speed P&A pallet / case labelling solution

Models

- » 910: for labels to 110 mm width
- » 920: for labels to 210 mm width
- » 930: for labels to 300 mm width

Printing characteristics

- » Thermal direct or thermal transfer printing method for labels up to A3
- » Print resolution: 203 dpi or 300 dpi

Label material

- » Running length: 800 m (optional 1,200 m)
- » Outer diameter: 395 mm ± 5 mm (optional 480 mm)
- » Label core: 76 / 152 mm
- » Low material warning

Operation

- » 5" touchscreen function for numeric entry
- » Optional: HMI 10" colour display
 - » with touchscreen function
 - » with alphanumeric entry
 - » multilingual user interface
 - » current label display

Interfaces

- » Integrated Ethernet port
- » High-speed RS-232 or RS-422 (optional: plus 2x RS-232 or RS-422)
- » Digital I/O (potential-free outputs)

Standard functions

- » Standard barcodes and 2D codes
- » Logos and graphics
- » Internal article database
- » Integrated real-time clock
- » Individually programmable counters
- » Fault diagnosis
- » Compressed air monitoring
- » Maintenance interval display

Ambient conditions

- » Operating temperature: 5 °C – 37 °C
- » Humidity: 20 % – 85 % relative, non-condensing
- » Electrical connection: 100 – 240 Volt; 50 – 60 Hz
- » Compressed air: 6 bar ½" BSP fixed, oil & water free

Frames and protective enclosure

- » H foot frame
- » Optional: machine enclosure made from steel plate, with inspection windows, service doors and automatic flap control

Certificates

- » CE certified (EU)
- » Optional: TR / EAC (RU)
- » Optional: SASO (SA)
- » Optional: UL 508 (US)

Additional options

- » RFID
- » Barcode verification (Vericoder)
- » Barcode validation (Scanner)
- » Alarm pole
- » Profibus / Profinet
- » Emergency stop
- » Height and side adjustment (manual / automatic)
- » Customer specific rest pallet handling
- » Special solutions for demanding ambient conditions
- » Enclosure in stainless steel and special colours available
- » Software:
 - » Middleware package: LogoSoft
 - » Label design: LEAP Express
 - » Management: LogoRemote
 - » Real-time connectivity
 - » Stand-alone

Spare parts / maintenance

- » Full spare parts available worldwide
- » 10 years guaranteed spare parts availability
- » Bespoke service support, preventive maintenance and telephone support

Models 910 / 920 / 930

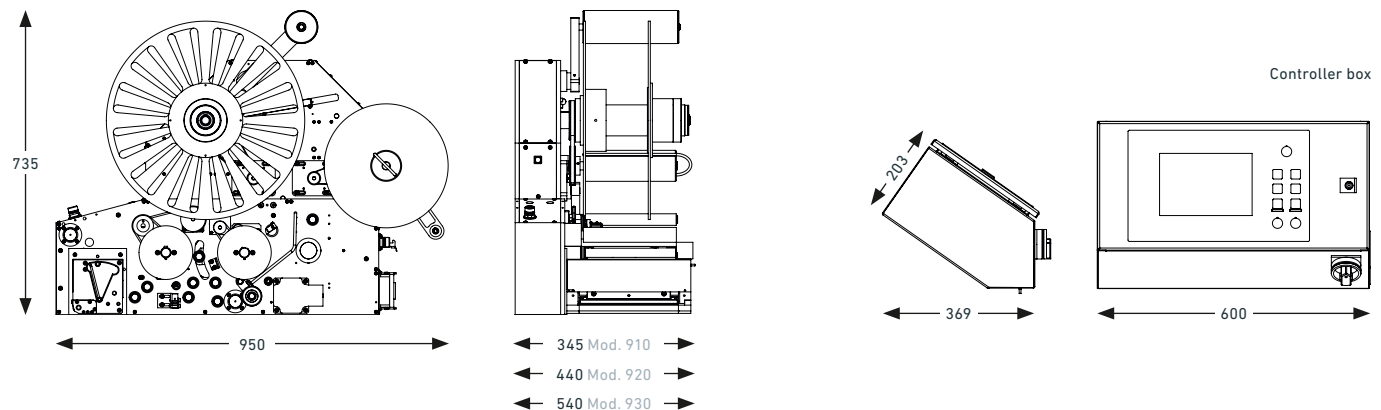

All dimensions in mm.